

THE MODERN ART OF DESIGN PROTECTION

Issues Relating to Design Protection After *Egyptian Goddess*

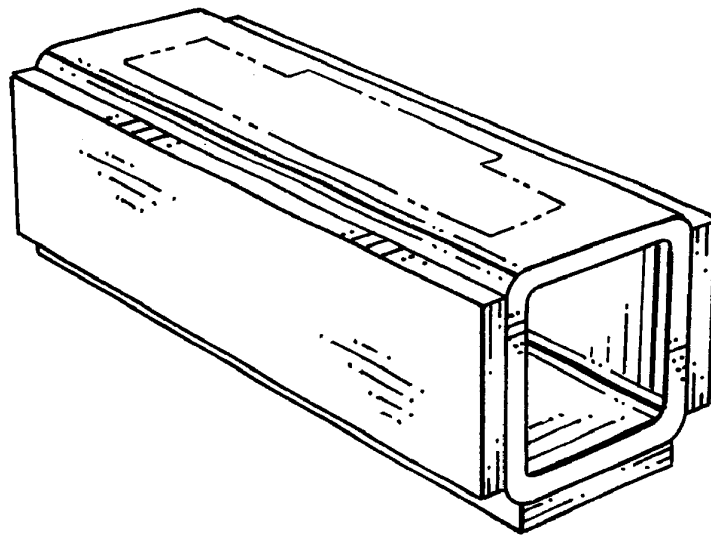

Julie Daulton jdaulton@merchantgould.com

Randy Hillson rhillson@merchantgould.com

Merchant & Gould, Minneapolis

Managing IP Webinar

May 19, 2010

The authors gratefully thank Merchant & Gould attorneys: Ben Tramm; Andy Lagatta; and, Heather Kliebenstein, draftsman Scott Engle, and the M&G Library Staff (Hope Porter, Chief Librarian) for their assistance.

Fashion: That, not necessarily beautiful, which makes what preceded it look stodgy, foolish, or inexpensive.

- - Leo Rosten

Moral victories don't count.

- - Savielly Grigorievitch Tartakower

They were more than lawyers. They were human beings.

- - tag line from current TV ad for a law firm

THE MODERN ART OF DESIGN PROTECTION

I. Introduction

On September 22, 2008, the United States Court of Appeals for the Federal Circuit decided *Egyptian Goddess*.¹ The decision was a rehearing, *en banc*, of a decision regarding design patent infringement to address the appropriate legal standard to be used in assessing claims of infringement. Ultimately, that court held that the "point of novelty" test could no longer be used in the analysis of a claim for design patent infringement, but rather the test for infringement remains the "ordinary observer test" set out by the Supreme Court in 1871.²

For a case which ultimately upheld a legal test that had been in place since 1871, the *Egyptian Goddess* decision has elicited a great deal of interest. It was the first time the Federal Circuit agreed to hear a design patent case *en banc*. Many *amici curiae* briefs had been filed, including from major corporations and bar associations. In fact, it has been asserted to represent the most important design patent case since 1871.³

Herein, the *Egyptian Goddess* decision is reviewed, along with its progeny. In light of these decisions, a review is made of design patent practice with practical recommendations to take into consideration when preparing, filing and prosecuting design patent cases. Also, in comments a brief comparison is made to current design protection in the U.S. under alternate protection approaches, i.e. copyright and unfair competition.

¹ *Egyptian Goddess Inc. v. Swisa, Inc.*, 543 F.3d 665 (Fed. Cir. 2008), *cert. denied* 129 S.Ct. 1917 (2009).

² *Gorham Co. v. White*, 81 U.S. 511 (1871).

³ Christopher V. Caran, *Egyptian Goddess v. Swisa: En Banc Federal Circuit Court Searches for the Rosetta Stone for Design Patent Jurisprudence*, Intellectual Property Today, Oct. 2008, at 31.

II. The Egyptian Goddess Decision

A. Factual and Procedural Background

Egyptian Goddess, Inc. (EGI) brought an action in the United States District Court for the Northern District of Texas, alleging that Swisa, Inc. and Dror Swisa (collectively "Swisa") had infringed one of its design patents, US D467,389. The '389 design patent is directed to a nail buffer, and it issued with one embodiment. Figures 1 and 4 from the '389 patent are shown below:

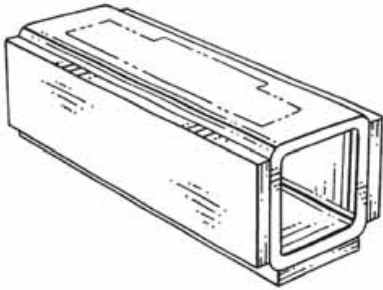

FIG. 1

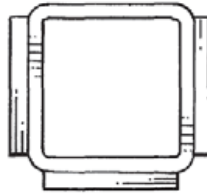
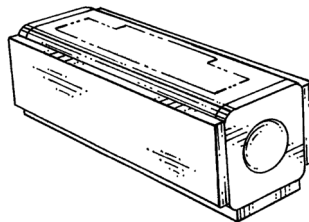

FIG. 4

The design patent included the statement, "the dashed outlines in the views of Figs. 1 and 6 showing the location of indicia are for illustrative purposes only and form no part of the claimed design." US D467,389 S issued December 17, 2002 from an application filed February 12, 2002 as a division of Application No. 29/149,507 filed October 11, 2001 and issued as U.S. Design Patent 459,548. US D459,548 issued with one embodiment:



The original design patent application had been filed with 14 figures, comprising the two embodiments. The Patent Office identified the two embodiments as two inventions and required restriction. The applicant provisionally elected one of the embodiments by telephone in the parent application. The first examination by the Patent Office indicated allowability of the first embodiment, which became the subject matter of D459,548. In the divisional application, which became U.S. D467,389, the Patent Office also issued a first action allowance.

The accused product was a nail buffer provided by Swisa, Inc. That nail buffer is similar in "rectangular" design to U.S. D467,389 but the Swisa buffer had a buffer on each of the four sides. The Swisa buffer is depicted below:

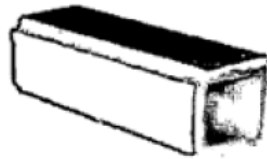

According to the Federal Circuit, the district court (N.D. Tex.) ruled that Swisa had not shown that the design of the patent was dictated solely by utilitarian purpose; therefore, the design was not invalid for being governed solely by function. In construing the claim, the district court sought to describe, in words, the design set forth in the patent, as follows:

A hollow tubular frame of generally square cross section, where the square has sides of length S , the frame has a length of approximately $3S$, and the frame has a thickness of approximately $T = 0.1S$; the corners of the cross section are rounded, with the outer corner of the cross section rounded on a 90 degree radius of approximately $1.25T$, and the inner corner of the cross section rounded on a 90 degree radius of approximately $0.25T$; and with rectangular abrasive pads of thickness T affixed to three of the sides of the frame,

covering the flat portion of the sides while leaving the curved radius uncovered, with the fourth side of the frame bare.⁴

Swisa moved for summary judgment of noninfringement, and the district court granted the motion. The district court concluded that in a design patent case, the patent holder must show both: (1) that the accused device is "substantially similar" to the claimed design under what is referred to as the "ordinary observer" test; and (2) that the accused device contains substantially the same points of novelty that distinguished the patented design from the prior art.

On comparison of the claimed design with the accused product, the district court had held that Swisa's product did not incorporate "the point of novelty" of the design patent, which the district court identified as the fourth, bare, side to the buffer.⁵

The district court noted in its decision that the parties disagreed as to the points of novelty in the '389 design patent. EGI had identified four elements of its design and had contended that the point of novelty was the combination of these four elements. The district court declined to address the question of whether the point of novelty could be found in that combination of elements because the court found that a single prior art reference contained all but one of the elements of the patented design. The referenced prior art was a Nailco design patent, U.S. 416,648, with FIGS. 1 and 2 pictured below:

⁴ *Egyptian Goddess Inc. v. Swisa, Inc.*, 2005 U.S. Dist. LEXIS 32931at *2 (N.D. Tex. March 3, 2005); *aff'd*, 543 F.3d 665 (Fed. Cir. 2008) (en banc); *cert. denied*, 129 S. Ct. 1917 (2009).

⁵ 2005 U.S. Dist. LEXIS 32931at *6.

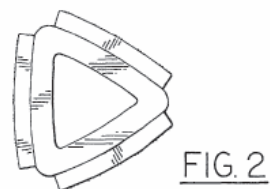
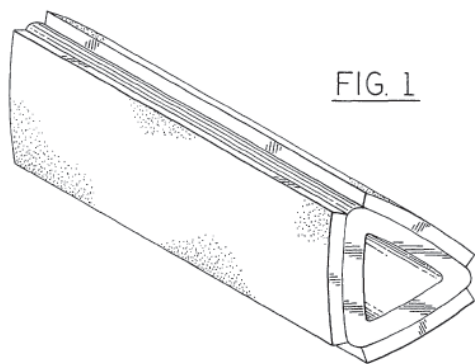

This prior art design patent was characterized by the district court as disclosing: "a nail buffer with an open and hollow body, raised rectangular pads, and open corners."⁶ The district court asserted that the only element of the '389 design patent, which was not present in the Nailco design patent, was the fourth side without a pad, thereby transforming the equilateral triangular cross-section of the Nailco design into a square cross-section. The district court concluded that because the Swisa product did not incorporate that point of novelty (the fourth side without a pad), then Swisa did not infringe EGI's '389 patent.⁷

EGI appealed, and a panel of the Federal Circuit Court affirmed.⁸ The panel had agreed with the district court that there was no issue of material fact as to whether the accused Swisa buffer "appropriates the point of novelty of the claimed design."⁹ The panel had stated that the point of novelty in a patented design "can be either a single novel design element or a combination of elements that are individually known in the prior art."¹⁰ Furthermore, the panel asserted that in order for a combination of individually

⁶ *Id.*

⁷ *Id.*

⁸ 498 F.3d 1354 (Fed. Cir. 2007).

⁹ *Id.*

¹⁰ *Id.* at 1357.

known design elements to constitute a point of novelty, "the combination must be a non-trivial advance over the prior art."¹¹

Ultimately, the panel determined that no reasonable juror could conclude that EGI's asserted point of novelty constituted a non-trivial advance over the prior art, and also observed that the design elements of the claimed design "were each individually disclosed in the prior art."¹² The panel did observe that because the Swisa buffers have raised abrasive pads on all four sides, and not just on three of the four sides as in the claimed design, there was no infringement because when considering the prior art and the nail buffer field, this difference cannot be considered minor.¹³

The Federal Circuit granted a rehearing *en banc* and asked the parties to address several questions including: (1) whether the point of novelty test should continue to be used as a test for infringement of design patent; (2) whether the court should adopt the "non-trivial advance test" as a means for determining whether a particular design feature qualifies as a point of novelty; (3) how the point of novelty test should be administered, particularly when numerous features of the design differ from prior art designs; and (4) whether district courts should perform formal claim construction in design patent cases.¹⁴

B. The Federal Circuit *En Banc* Decision¹⁵

The Federal Circuit began by asserting that the starting point for any discussion of the law of design patents is *Gorham*.¹⁶ In that decision, which concerned handles for tableware, the Supreme Court noted that the test of identity of design must be "sameness

¹¹ *Id.*

¹² *Id.* at 1358.

¹³ *Id.*

¹⁴ 256 Fed. Appx. 357 (Fed. Cir. 2007).

¹⁵ 543 F.3d 665 (Fed. Cir. 2008), *cert. denied* 129 S.Ct. 1917 (2009).

¹⁶ *Gorham Co v. White*, 81 U.S. 511 (1871).

of appearance" and that slight variances "will not destroy substantial identity."¹⁷ Gorham noted that designs need not be the same "to the eye of an expert" because if that were the test, there never could be infringement because "human ingenuity has never yet produced a design, in all its details, exactly like another."¹⁸

In *Gorham*, the Supreme Court set forth the often-cited test that "[I]f, in the eye of an ordinary observer, giving such attention as a purchaser usually gives, two designs are substantially the same, if the resemblance is such as to deceive such an observer, inducing him to purchase one supposing it to be the other, the first one patented is infringed by the other."¹⁹ This test is often referred to as the "ordinary observer" test. In articulating this test, the Supreme Court referenced the "purchaser." The "purchaser" has been interpreted to mean the ordinary observer in the relevant market, who may be someone other than the actual purchaser.

An issue, however, arises in design patent infringement assessments, when the patented design includes many "prior art" features. For example, when the patented design includes a single distinguishing characteristic from a prior art, unpatented design, a problem with the ordinary observer test was the risk that in applying the test to find infringement, a court could overlook the fact that the reason the accused product looks like a design patent is that it incorporates the design features of the prior art, and not the design features that distinguish the patented design from the prior art.²⁰

¹⁷ *Id.* at 527.

¹⁸ *Id.*

¹⁹ *Id.* at 528.

²⁰ *Egyptian Goddess*, 543 F.3d at 671.

As a result of this issue, in cases such as *Litton Systems*,²¹ the Federal Circuit has held that proof of similarity under the ordinary observer test is not enough to establish design patent infringement. Rather, according to the court in *Litton Systems*:

For a design patent to be infringed . . . no matter how similar two items look, ‘the accused device must appropriate the novelty in the patented device which distinguishes it from the prior art.’ That is, even though the court compares two items through the eyes of the ordinary observer, it must nevertheless, to find infringement, attribute their similarity to the novelty which distinguishes the patented device from the prior art.²²

Thus, in cases decided after *Litton Systems*, the Federal Circuit interpreted the law to require that the test for design patent infringement requires: (a) consideration from the perspective of an ordinary observer; and (b) use of the particular novelty of the claimed design.

As noted by the Federal Circuit in *Egyptian Goddess*, in various decisions the "ordinary observer" test and "point of novelty" test were described as conjunctive; and in others, they been described as "two distinct tests."²³

In *Egyptian Goddess*, the point of novelty test was characterized as easy to apply in simple cases in which the claimed design is based on a single prior art reference and that departs from that prior art reference in a single aspect. In such cases, it was argued, it is a simple matter to identify the point of novelty to determine whether the accused design has appropriated the point of novelty.²⁴

In *Egyptian Goddess*, the Federal Circuit noted, however, that the point of novelty is difficult to apply where the claimed design has numerous features that can be

²¹ *Litton Sys., Inc. v. Whirlpool Corp.*, 728 F.2d 1423 (Fed. Cir. 1984).

²² *Id.* at 1444.

²³ 543 F.3d at 671.

²⁴ *Id.*

considered points of novelty, or when multiple prior art references are at issue, and the claimed design consists of a combination of features, each of which could be found in one or more of the prior art designs.²⁵

After an exhaustive review of decisions in the *en banc* decision, the Federal Circuit concluded that the point of novelty test, as a second and freestanding requirement for proof of design patent infringement: is inconsistent with the ordinary observer test laid down in *Gorham*; is not mandated by precedent; and is not needed to protect against unduly broad assertions of design patent rights.²⁶ In general, the court read prior decisions as "applying a version of the ordinary observer test in which the ordinary observer is deemed to view the differences between the patented design and the accused product in the context of the prior art."²⁷ According to the court, when the differences between the claimed and accused design are viewed in light of the prior art, the attention of the hypothetical ordinary observer will be drawn to those aspects of the claimed design that differ from the prior art; and when the claimed design is close to prior art designs, small differences between the accused design and the claimed design are likely to be important to the eye of the hypothetical ordinary observer.²⁸

The Court noted that because "the patentee bears the ultimate burden of proof to demonstrate infringement by preponderance of the evidence," the patentee has a burden of production as to any comparison of prior art would be needed in applying the ordinary observer test.²⁹

As noted above, in making its *en banc* review, the Federal Circuit raised the issue

²⁵ *Id.*

²⁶ *Id.* at 672

²⁷ *Id.* at 676.

²⁸ *Id.*

²⁹ *Id.* at 679.

of whether the trial courts should conduct claim construction in design patent cases. In general, the Federal Circuit observed that "the preferable course ordinarily will be for a district court not to attempt to 'construe' a design patent by providing a detailed verbal description of the claimed design."³⁰ However, the court also observed that it would not be reversible error, absent a showing of prejudice, for a district court to prepare such a description.³¹

In the final portion of the opinion, the Federal Circuit applied the test and concluded that EGI failed to meet its burden of showing, by a preponderance of the evidence "that an ordinary observer, taking into account the prior art, would believe the accused design to be the same as the patented design."³² Thus, the same ultimate result was reached, as was reached by the district court.

III. Commentary Following the *Egyptian Goddess* Decision

In commentary following *Egyptian Goddess*, it was asserted that "design patent owners have a reason to celebrate the decision."³³ This position is curious, given that the Federal Circuit: (1) affirmed a test that has been in existence since at least 1871; (2) acknowledged that while there should be no such thing as a "point of novelty" test, stated that evaluation of the point of novelty is an inherent part of applying "the ordinary observer" test; (3) did not fully rebuke a district court practice of creating detailed written characterizations of designs; and (4) found no infringement.

³⁰ *Id.*

³¹ *Id.*

³² *Id.* at 682. It is noted by these authors that such a statement would suggest that the "deception" portion of the ordinary observer test is a requirement of infringement, rather than an example of infringement.

³³ Rebecca L. Hanovice, *Egyptian Goddess revises design patent analysis*, Nat'l Law J., Dec. 1 2008, at S3.

In spite of this result, again, after the *Egyptian Goddess* decision, some commentators have asserted that "design patents have sharper claws now, and thus merit careful consideration."³⁴ The reason for such an assertion, of course, has been that by reaffirming the ordinary observer test, *Egyptian Goddess* arguably makes it easier for plaintiffs to assert a design patent because the stringent requirements of the point of novelty test are avoided.

One reason at least one commentator asserted that the *Egyptian Goddess* decision is considered to be good for design patent holders is that the "Federal Circuit . . . has deprived alleged infringers of their two major weapons in avoiding infringement."³⁵ The two major weapons referred to by that commentator are, of course, the point of novelty test and the district court creating a written characterization of the design.

IV. Selected Federal Circuit Decisions Post *Egyptian Goddess*

The Federal Circuit has issued three design patent decisions of particular interest post *Egyptian Goddess*, namely: *International Seaway Trading v. Walgreens*; *Crocs v. International Trade Commission*; and *Richardson v. Stanley Works*.

A. International Seaway Trade v. Walgreens³⁶

In *International Seaway v. Walgreens*, the Court was concerned with design patents relating to "casual, lightweight footwear" i.e. "clogs." More specifically, Walgreens and Touch Sport Footwear were accused of infringing design patents depicting footwear as follows:

³⁴ *Id.*

³⁵ Perry J. Saidman, *Egyptian Goddess Exposed! But Not In the Buff(er)*, 20 J. Pat. & Trademark Off. Soc'y 884-85 (2008).

³⁶ *Int'l Seaway Trading Corp. v. Walgreens Corp.*, 589 F.3d 1233 (Fed. Cir. 2009).



Fig. 1

U.S. D529,263

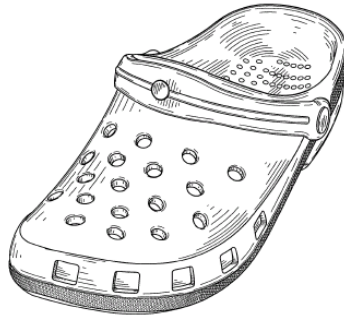

Fig. 1

U.S. D545,032

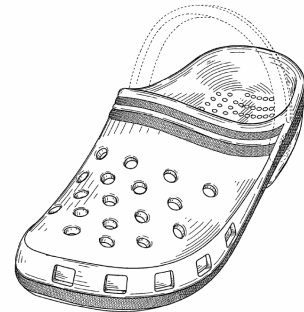

Fig. 1

U.S. D545,033

The district court had granted summary judgment of invalidity, finding all three patents anticipated by the Crocs design patent D517,789, depicting footwear as follows:

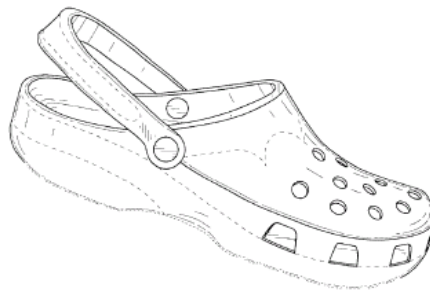

FIG.1

U.S. D517,789

In granting summary judgment, the district court had asserted that the ordinary observer test was the sole test of design patent invalidity under 35 U.S.C. § 102.³⁷ In granting the summary judgment, the district court had compared exterior portions of the design, but not the insoles, to the prior art.³⁸ The district court conclusion was that the

³⁷ *Id.*

³⁸ *Id.*

insoles should not be compared, since they are not visible during normal use, without regard to whether those portions are visible at the point of sale.³⁹

The Federal Circuit began its analysis by observing that *Egyptian Goddess* concerned the test for infringement, and that it had reserved the question in *Egyptian Goddess* as to whether the same test is the test for invalidity.⁴⁰ The Federal Circuit concluded that while the district court was correct in stating that the ordinary observer test was the test for invalidity, the district court was incorrect in its application of the test by refusing to examine the insoles. The Federal Circuit agreed with the district court that *Egyptian Goddess* necessarily required a change in the test for anticipation (validity assessment).⁴¹

In *International Seaway*, the Federal Circuit examined the word “original” appearing in 35 U.S.C. § 171, which is required for a design patent. The court acknowledged that the meaning of “original” is not clear, and speculated that it may be related to the concept of originality in copyright, which means “original with the author.” In any event, observed the court, the courts had not construed the word “original” as requiring that design patents be treated any differently than utility patents.⁴²

In the case of infringement, and applying the ordinary observer test, the Federal Circuit explained that a court compares the patented design with the accused design; and in the case of anticipation, the court compares the patented design with the alleged anticipatory reference.⁴³ According to the Federal Circuit, in applying the point of novelty test, at least in the past, the courts had looked at where the accused design

³⁹ *Id.*

⁴⁰ *Id.* at 1237-38.

⁴¹ *Id.* at 1238.

⁴² *Id.* at 1237-38

⁴³ *Id.*

appropriated the points of novelty of the patented design. In the case of anticipation, in the past, the court compared the patented design with the alleged anticipatory reference to see if it appropriated the points of novelty in the prior art reference.

The court observed that in *Egyptian Goddess*, the Federal Circuit abandoned the point of novelty test for design patent infringement and held that the ordinary observer test should serve as the sole test.⁴⁴ The court then concluded that the ordinary observer test must logically be the sole test for anticipation as well.⁴⁵ Using this test for anticipation, it was asserted, would prevent an inconsistency from developing between the infringement and anticipation analyses, and would continue a “well-established practice of maintaining identical tests for infringement and anticipation.”⁴⁶

As to the district court’s conclusion that the law requires a court to consider only those portions of the product that are visible during normal use, regardless of whether those portions are visible at the point of sale, the Federal Circuit found error. Thus, it remanded for determination of whether the differences between the insole pattern in the patents-in-suit and in the prior art bar a finding of anticipation or obviousness.

B. *Crocs v. International Trade Commission (ITC)*⁴⁷

In *Crocs v. ITC*, the Federal Circuit reviewed a decision by the International Trade Commission that none of the interveners had infringed Crocs U.S. D517,789. The ITC had also found a related utility patent U.S. 6,993,858 to have been obvious.

⁴⁴ *Id.* at 1239.

⁴⁵ *Id.* at 1240.

⁴⁶ *Id.*

⁴⁷ *Crocs Inc. v. Int’l Trade Comm’n.*, 2010 U.S. App. LEXIS 3793 (Fed. Cir 2010).

The design portion of the case related a design patent on the famous Crocs footwear. A depiction from design patent US D517,789 is as follows:

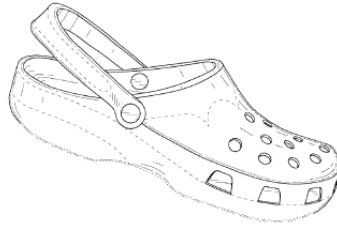

FIG.1

U.S. D517,789

The administrative judge had concluded that the accused infringers did not violate §1337. Specifically, the administrative judge had found that the ‘789 design patent was not infringed, and that the Crocs products did not satisfy the so-called “technical prong” of the domestic industry requirement. In reaching this latter decision, the administrative judge found that Crocs’ own product was not covered by the patent.⁴⁸

The administrative judge provided a detailed verbal claim construction to the design patent:

In summary, when the ‘789 patent is considered as a whole, the visual impression created by the claimed design includes: footwear having a foot opening with a strap that may or may not include any patterning, is attached to the body of the footwear by two round connectors, is of uniform width between the two round connectors, has a wrench-head like shape at the point of attachment, and extends to the heel of the shoe; with round holes on the roof of the upper placed in a systematic pattern; with trapezoid-shaped holes evenly spaced around the sidewall of the upper including the front portion; with a relatively flat sole (except for upward curvature in the toe and heel) that may or may not contain tread on the upper and lower portions of the sole, and scalloped indentations that extend

⁴⁸ *Id.* at *9.

from the side of the sole in the middle portion that curvature toward each other.⁴⁹

Based on the description, the administrative judge found that certain products did not infringe because the strap was not of uniform thickness and did not extend to the heel of the shoe. Other products were found not to infringe for same reason, plus they did not have round holes in the upper portion. Still others were found to not infringe because they had at least one of the following: a strap that did not have uniform thickness and did not extend to the heel of the shoe; holes in the upper that were not round; holes in the upper that were placed in a web-shape and not systematic pattern; or a tread pattern that covered the entire sole.⁵⁰

The Commission confirmed the finding of no infringement and no domestic industry for the '789 design patent.⁵¹

In *Crocs*, the Federal Circuit observed, “in *Egyptian Goddess*, this court warned that misplaced reliance on the detailed verbal description of the claimed design risks undue emphasis on particular features of the design rather than examination of the design as a whole.”⁵²

⁴⁹ *Id.* at *9-10.

⁵⁰ *Id.* at 10.

⁵¹ *Id.* at 11.

⁵² *Id.* at *13. Actually, what the Federal Circuit in “*Egyptian Goddess* stated was:

It is important to emphasize that a district court’s decision regarding the level of detail to be used in describing the claimed design is a matter within the court’s discretion, and absent to showing of prejudice, the court’s decision to issue a relatively detailed claim construction will not be reversible error. At the same time, it should be clear that the court is not obligated to issue a detailed verbal description of the design if it does not regard verbal elaboration as necessary or helpful. In addition, in deciding whether to attempt a verbal description of the claimed design, the Court should recognize the risks entailed in such a description, such as the risk of placing undue emphasis on particular features of the design and the risk that a finder of fact will focus on each individual described feature in the verbal description rather than on the design as a whole. In this case, for example, the district court came up with a detailed verbal description of the

In these authors' opinions, the court's comments in *Egyptian Goddess* hardly stand as a strong caution against highly detailed verbal descriptions. The very detailed description used in *Egyptian Goddess* was accepted by the Federal Circuit; and while the court issued a "caution," in no manner did it criticize the highly detailed description or suggest that it was inappropriate. Indeed, one questions whether there would have been criticism in *Crocs* of the detailed description had the ITC gotten the detail of the description accurate. Further, the finding of no infringement in *Egyptian Goddess* appeared to have been based on detail that was in the highly detailed verbal description, and the court completely failed to consider the possibility of infringing a design patent by adding a feature to a protected design.

Nevertheless, in *Crocs*, the Federal Circuit stated, "this case shows the dangers of reliance on a detailed verbal claim construction," in the instance of interpreting a design

claimed design. We see no inaccuracy in the court's description, and neither party has pointed to any prejudice resulting from the court's interpretation. Yet it is not clear that the considerable effort needed to fashion the verbal description contributed enough to the process of analyzing the case to justify the effort.

While it may be unwise to attempt a full description of the claimed design, the Court may find it helpful to point out, either for a jury or in the case of a bench trial by way of describing the court's own analysis, various features of the claimed design as they relate to the accused design and the prior art. In a case such as this one, for example, there would be nothing wrong with the court pointing out to a jury that in the patented design, only three sides have buffers attached, while in the accused product (and in the three-sided Nailco patent), all of the sides have buffers attached. It would similarly be permissible for the court to point out, that for example, although the Falley Buffer Block has four sides, it is not hollow, unlike the design of the '389 patent, the Nailco patent, and the accused Swisa product

Providing an appropriate measure of guidance to a jury without crossing the line and unduly invading the jury's fact-finding process is a task that trial courts are very much accustomed to, and any attempt by an appellate court to guide that process in detail is likely to do more harm than good. We therefore leave the question of verbal characterization of the claimed designs to the discretion of trial judges, with the proviso that as a general matter, those courts should not treat the process of claim construction as requiring a detailed verbal description of the claimed design, as would typically be true in the case of utility patents.

543 F.3d at 679-80.

patent.⁵³ The Federal Circuit concluded that the claim construction focused on particular features of the ‘789 patent design and led the Administrative Judge and Commission away from consideration of the “design as a whole”⁵⁴ and became a “mistaken checklist for infringement.”⁵⁵ As an example, in *Crocs*, Figure 1 of the ‘789 design patent shows the strap bulging to a greater width at the middle of the strap than on the far left of the figure. Thus, it was asserted by the Federal Circuit that the design figure does not require uniform width between the two round connectors. Also, the Federal Circuit observed Fig. 4 of the ‘789 patent shows the holes not evenly spaced, but that, nonetheless, the written claim description required a uniform strap width and uniform hole spacing.⁵⁶

The Federal Circuit stated that the administrative judge and the Commission needed to apply the ordinary observer test to the “design shown in the figures 1-7.”⁵⁷

The court then went on to make the following observations:⁵⁸

1. In determining whether an accused product infringes a patented design, the ordinary observer test is to be applied without any “point of novelty” perspective.

2. To show infringement under the proper test, one would need to show that an ordinary observer, familiar with the prior art designs, would be deceived into the believing that the accused product is the same as the patented design.⁵⁹

3. When the differences between the claim and the accused design is viewed in light of the prior art, the attention of the hypothetical ordinary observer may be drawn to those aspects of the claimed design that differ from the prior art.

⁵³ 2010 U.S. App LEXIS 3793 at *14.

⁵⁴ *Id.*

⁵⁵ *Id.* at *16-17.

⁵⁶ *Id.* at *14-15.

⁵⁷ *Id.* at *15.

⁵⁸ *Id.* at *15-16.

⁵⁹ Again, this appears to also be what happened per *Egyptian Goddess*.

4. If the claimed design is close to the prior art design, small differences between the accused design and the claimed design are assumed more important to the eye of the hypothetical ordinary observer.

5. The ordinary observer, however, will likely attach importance to those differences depending on the overall effect of those differences on the design.

6. Even if the claimed design simply combines old features in the prior art, it may still create an overall appearance deceptively similar to the accused design and in that case, the court will uphold a finding of infringement.

7. Thus, the deception that arises is a result of the similarities in the overall design, not the similarities in the ornamental features in isolation.

The Federal Circuit then went on to observe that in doing side-by-side comparisons between the '789 design and the accused products, the ordinary observer would be deceived into believing the accused products are the same as the patented design.⁶⁰

The court noted that the requirement under § 1337 of the domestic industry (i.e. the test for the “technical prong” of the industry requirement) is “essentially the same as for infringement.”⁶¹ Thus, the ordinary observer test should be used to compare Crocs’ own shoe products to the ‘789 patent design, with a side-by-side comparison. After making such a comparison, the Federal Circuit concluded that Crocs did satisfy the technical prong.

⁶⁰ If anything, these comments would suggest that the problem the Federal Circuit had with the verbal description is that the Federal Circuit simply did not see the description as accurate. It would appear that the Federal Circuit would have been satisfied if the verbal description had been more accurate in *Crocs*.

⁶¹ 2010 U.S. App Lexis 3793 at *19.

C. *Richardson v. Stanley Works*⁶²

In *Richardson*, the design patent at issue, D507,167, depicted a “multifunction stud climbing and carpentry tool,” referred to as the “Richardson Stepclaw.” An example drawing from the design patent is below:

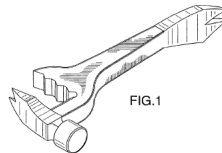

D507,167

The ‘167 design patent is owned by Richardson. Stanley had obtained its own design patent for its line of tools, sold under the name “Fubar,” see D562,101. In *Richardson*, it was stated that “all five versions of the tool [Stanley] are built around the same basic Fubar design.”⁶³ That “basic” design was characterized by the Federal Circuit as represented by Figs. 1 and 5 of the ‘101 design patent as follows:

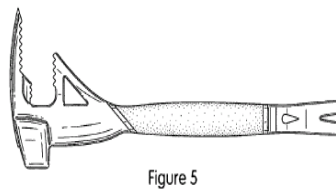
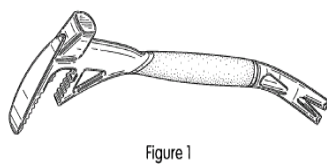

Richardson had asserted that the Fubar tools infringed U.S. D507,167.

The district court had distinguished, as part of its claim construction, ornamental aspects from functional aspects of the Richardson design, and then determined that an ordinary observer, after discounting the functional elements of the Richardson design,

⁶² *Richardson v. Stanley Works*, 2010 U.S. App. LEXIS 4895 (Fed. Cir 2010).

⁶³ *Id.* at *2.

would not be deceived into thinking that any of Fubar Tools were the same as the Richardson Stepclaw. The district court therefore concluded that the overall visual effect of the Fubar was not substantially similar to that of the Stepclaw, and, thus, that the ‘167 patent had not been infringed.

Richardson appealed, arguing that *Egyptian Goddess* required that the patented design be compared in its entirety, and that the comparison be made from the perspective of an ordinary observer.⁶⁴ Richardson asserted that the claim construction performed by the district court is necessary only for designs that contain “purely functional” elements, and that a design element is “purely functional” only when the function cannot be performed by any other design.⁶⁵

The Federal Circuit disagreed that the district court erred in its claim construction. The Federal Circuit cited, with approval, its previous *Oddzon* decision⁶⁶ in which it had held “where a design contains both functional and non-functional elements, the scope of the claim must be construed in order to identify the non-functional aspects of the design as shown in the patent.”⁶⁷

The Federal Circuit then observed that while in *Egyptian Goddess* it had abandoned the point of novelty test and had proposed that a preferable course would include no attempt to construe a design patent claim, the Federal Circuit had emphasized

⁶⁴ *Id.* at *4. This argument gets to the heart of these authors’ critiques of the Federal Circuit’s interpretation of the “ordinary observer” test. Because the Federal Circuit appears to assert that the “deception” phrasing is the “sole measure” under the ordinary observer test, then it appears that one can take a patented design and merely add enough feature to it so that the viewer would not be “deceived” into thinking that the accused product is the design. This result would ignore the fact that in designing the accused product, the accused may have incorporated the protected design and merely added enough feature to it (while retaining ornamental design aspects) to avoid deception. These authors believe that the Federal Circuit has not reached the end of its struggles with defining design patent infringement for at least this reason.

⁶⁵ *Id.* at *4-5.

⁶⁶ *OddzOn Prods. Inc. v. Just Toys, Inc.*, 122 F.3d 1396 (Fed. Cir. 1997).

⁶⁷ *Richardson*, 2010 U.S. App. LEXIS 4895 at *5-6.

that there are a number of claim scope issues in which a court's guidance would be useful to a fact finder; and among them would include the distinction between the "functional and ornamental aspects of a design."⁶⁸

With respect to Richardson's design, the Federal Circuit observed that the patented design is for a multi-functional tool that has several functional components, and that it has made clear that a design patent, unlike a utility patent, limits protection to the ornamental design of the article. It further asserted that if a patented design is primarily functional rather than ornamental, the patent is invalid.⁶⁹ However, according to the Federal Circuit, when the design also contains ornamental aspects, "it is entitled to a design patent scope as limited to those aspects alone and does not extend to any functional elements of the claimed article."⁷⁰ The Federal Circuit then concluded that Richardson's multifunction tool comprises several elements that are driven purely by utility:

As the district court noted, elements such as a handle, the hammer-head, the jaw, and the crowbar are dictated by their functional purpose. The jaw, for example, has to be located on the opposite end of the hammerhead such that the tool can be used as a step. The crowbar, by definition, needs to be on the end of the longer handle such that it can reach into narrow spaces. The handle has to be longest arm of the tool to allow for maximum leverage. The hammer-head has to be flat on its end to effectively deliver force to the object being struck.⁷¹

Richardson had also argued that the court erred in not including drawings from the patent in its claim construction. The Federal Circuit disagreed observing: (i) the district

⁶⁸ *Id.* at *6.

⁶⁹ *Id.* at *7.

⁷⁰ *Id.* at *7. These authors are aware that in *Egyptian Goddess*, the court had concluded that the aspects of the design were not purely functional. This conclusion, however, begs the question. Because the Federal Circuit approved that all aspects of Richardson's design were purely functional, it would seem reasonable that they should have, for consistency, also concluded that at least the emery board aspect of the accused design in *Egyptian Goddess* was also purely functional. Thus, why did it matter that a fourth board was present in the accused design?

⁷¹ 2010 U.S. App. LEXIS 4895 at *7-8.

court's claim construction did not necessarily exclude the drawings; (ii) the entire construction was based on what was shown and described the '167 patent; and (iii) the purpose of the claim construction was simply to highlight the ornamental aspects of Richardson's design.⁷²

The Federal Circuit also affirmed non-infringement observing that the only similarity to the Stanley Fubar related to unprotectable functional elements.⁷³ The Federal Circuit also ruled that the district court permissively denied Richardson's motion for a jury trial.

VI. Some Questions / Observations

A. What happens when there is an improvement patent or incorporation of another's concept with addition/modification?

Compare and contrast the Federal Circuit treatment to the following scenario under utility patent and design patent principles.

- Inventor protects concept X. Accused implements product X'. Is there an infringement?

Under utility patent principles, assuming that the scope of the patent claim is X, and the claim is not closed ended, in determining whether X' is an infringement, the court would look to see whether X' uses X. Because it does, infringement would be found.

In design patent practice, however, the Federal Circuit would say that the sole test is whether an ordinary observer looking at X' would be deceived into thinking that it was

⁷² *Id.* at *13.

⁷³ *Id.* at *10.

X. If an ordinary observer distinguishes between X' and X, then X' is not infringement, even though it incorporates X.⁷⁴

Is there any basis in the logic of intellectual property protection under Title 35 that justifies this distinction?

B. Is what is good for the goose also good for the gander, in the ordinary observer test?

According to the Federal Circuit, in a proper application of the ordinary observer test, the applier of the test can be directed to disregard a purely functional component of the protected design; and a feature can be “purely functional” even if it can implemented in a different manner. Should the bench or jury similarly ignore “purely functional” components of the accused design?

In *Egyptian Goddess*, arguably the main distinction between the two designs was the application of a fourth emery board to the otherwise blank side or undefined side of the protected design. Arguably, the emery board itself is “purely functional,” so it would appear that the two products were nearly identical with respect to the non-functional portions of the designs, e.g. the substrate.

C. In a design patent, how should one interpret an undefined surface?

In many design patents, selected surfaces are simply undefined. They are not shaded to show particular surface characteristics; rather, they are simply left blank. A reasonable argument is that it was the intent of the designer to simply not define the

⁷⁴ The *Egyptian Goddess* test makes every design patent claim, in effect, closed ended, i.e. exclusive, or nearly so; the analogy to utility patents being the claim is interpreted as using the preamble “consisting essentially of” or possibly “consisting of” instead of “comprising.”

presence or absence of anything in that space. That is, the designer would consider something else to incorporate the potential design, as long as it has the defined features, without regard to what is placed within that space.⁷⁵

The Federal Circuit would appear to disagree, given the direction of the *Egyptian Goddess* decision.⁷⁶ The design patent at issue in *Egyptian Goddess* had no specific definition provided in the fourth side. The phantom lines indicate possible labeling, but there is no specific surface feature provided in the region.

Arguably, the defendant in *Egyptian Goddess* merely added structure to the blank space--an extra emery board. The Federal Circuit, applying the deception test, concluded no infringement. But was that a proper interpretation of the design claim? The design claim arguably left that space as simply undefined. And, should the question have been whether the ordinary observer would have perceived the protected design features as having been appropriated, without specifying the presence or absence of structure on that surface?

D. How should dominant/serviant claim relationships be handled?

Consider the practice used by some attorneys, when preparing design applications, to provide multiple embodiments showing basically the same unit, but with different portions depicted in phantom or broken lines. The Patent Office will often issue a

⁷⁵ In effect, the inventor would view the design patent claim as open or inclusive.

⁷⁶ In *Egyptian Goddess*, the court cited with approval a highly detailed verbal description but with cautions. In *Crocs*, the court stated it cautioned against this conduct, but seemed to have as its principal problem that the verbal description was not detailed and accurate enough. In *Richardson*, the court then saw there are certainly instances in which the detailed verbal description (piecing apart the design) is useful such as separating functionality and ornamentality. Thus, in spite of the Federal Circuit's comments, the district courts appear to be guided by the Federal Circuit to use highly detailed verbal descriptions, as long as they are accurate.

restriction requirement between the various designs, even though they only differ with respect to how much, if any, is shown in phantom or broken lines.

In many cases, the holder of the design patents believes that each covers the commercial product. With respect to its interpretation in infringement, however, the Federal Circuit would seem to be driving in a different direction, or at least, an inconsistent one. If two designs can be distinguished, the court would appear to suggest that both cannot use the protected design, given the “deception” test as stated and emphasized.

VII. Selective Choice of Drawings May Allow Patentees to "select" Their Own Infringement Test.

A. Background

United States design patent principles allow the applicant a number of options in presenting drawings of a design patent claim. For example, portions of the drawing can be presented in phantom lines.⁷⁷ Portions can be shown with broken lines to indicate variability in dimension and/or proportion.⁷⁸ Drawings can be lined for color, or color can be left out,⁷⁹ and drawings can be detailed for texture, or texture can be left undefined.⁸⁰

Indeed, for a given selected design, a number of different sets of drawings can be prepared. For example, phantom lines can be applied to "prior art" aspects of a design, so that a patent holder can focus attention, for that particular embodiment, on the new feature or "point of novelty." If there are a number of such features, by showing those features as

⁷⁷ 37 C.F.R. §1.152.

⁷⁸ §1503.02 Manual of Patent Examining Procedure, 8th ed., rev. 7.

⁷⁹ *Id.*

⁸⁰ *Id.*

solid lines and other portions in phantom, again the patent holder can direct attention where desired, with respect to the evaluation of infringement.

The Patent Office will often issue a restriction requirement between two sets of drawings in a patent application when they only differ by the features depicted in (or not depicted in) phantom lines, and/or by break lines.⁸¹ Assuming a court will acknowledge the differences in the scope of the claims recognized by the Patent Office when the Patent Office issued the restriction requirement, the test for infringement and analysis with respect to the "broader" claim will need to be applied in a manner overlooking the phantom line portions in making a comparison. This will, in effect, result in a point of novelty test for infringement/validity.

B. Hypothetical Variations of *Egyptian Goddess*

In the following parts of this section, examined are: the subject of U.S. design D467,389 (the design patent at issue in *Egyptian Goddess*); the district court's verbal characterization of the design (found acceptable by the Federal Circuit); and the Federal Circuit's test in the context of exploring variations possible in the design patent drawings, and whether they might have changed the outcome.

More specifically, in the following portions of this section, the authors suggest alternative design drawings that may have been used in applying for protection on the *Egyptian Goddess* design. These authors do not wish to suggest here that each and every variation would have been allowed over the prior art; this would involve a full assessment of the prior art on obviousness issues. Each variation, however, arguably distinguishes the triangular prior art Nailco reference, which was cited as the key reference.

These authors also take no position as to whether changes in the drawings from

⁸¹ *Id.*

solid line to phantom line or phantom line to solid line during prosecution, would have been accepted by the Patent Office. Converting a phantom line to a solid line would rarely raise a new matter issue with the Patent Office. However, changing from a solid line to a phantom line seems more likely to raise a new matter rejection, although it does not appear to be proscribed.⁸²

As a reminder, in *Egyptian Goddess*, the district court had characterized the design as follows:

A hollow tubular frame of generally square cross section, where the square has sides of length S, the frame has a length of approximately 3S, and the frame has a thickness of approximately $T = 0.1S$; the corners of the cross section are rounded, with the outer corner of the cross section rounded on a 90 degree radius of approximately 1.25T, and the inner corner of the cross section rounded on a 90 degree radius of approximately 0.25T; and with rectangular abrasive pads of thickness T affixed to three of the sides of the frame, covering the flat portion of the sides while leaving the curved radius uncovered, with the fourth side of the frame bare.⁸³

This language is now examined for how a design patent can be modified in its preparation, to manage issues created by such statements.

1. “A hollow tubular frame of generally squared cross-section, where the square has sides of length S.”

Broken lines could have been used in the design patent figures to prevent the

⁸² *Id.* at § 1504.04(I) p. 1500-38: “An amendment that changes the scope of a design by either reducing certain portions of the drawing to broken lines or converting broken line structure to solid lines is not a change in configuration as defined by the court in *Salmon*. The reason for this is because applicant was in possession of everything disclosed in the drawing at the time the application was filed” (citing *In re Salmon*, 705 F.2d 1579 (Fed. Cir. 1983)).

⁸³ Because design patents extend for 14 years from issuance, and because double patenting rejections will not be raised when the Patent Office issues a restriction requirement, this practice from the Patent Office can provide an advantage in extending protection well past the initial 14 years. While in many instances of design protection, the popularity of the design will not extend 14 years, certainly there will be instances where it does.

suggestion that the design was necessarily limited to a “square” cross-sectional shape, for example as follows:

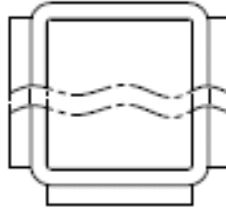

As to “hollow,” phantom lines could have been used, allowing for alternate interpretation, for example as follows:

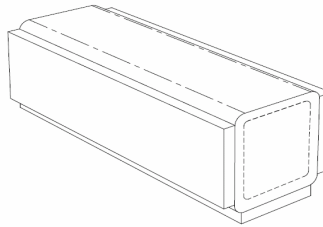

2. “The frame has a length of approximately $3S$.”

Broken lines could have been used to avoid the implication of any specific length/cross-section ratio as follows:

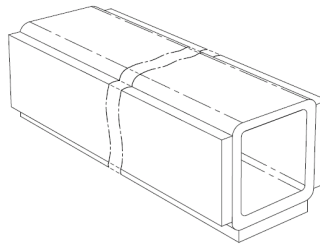

3. “The frame has a thickness of approximately $T = 0.1S$ ”.

Of course, if broken lines were used to allow for variation in the lengths of the sides (S) as discussed in at point 1 above, the proportions of thickness to side length could

no longer be specified. In addition, if phantom lines were used to prevent the implication of hollowness versus solidness, tubular thickness would no longer be relevant.

4. “The outer corners of the cross-section rounded on a 90 degree radius of approximately $1.25T$.”

If phantom lines were used to avoid the implication of a thickness T (i.e., solid versus hollow construction), there would be no radius ratio to identify. In any event, phantom lines could have been used, as shown below, to avoid specifying a corner rounded definition altogether.

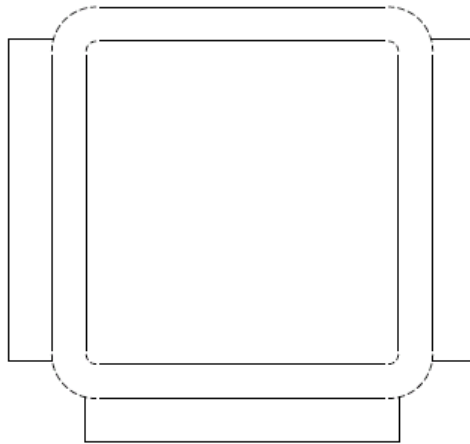

5. “and the inner corner of the construction rounded on a 90 degree radius of approximately $0.25T$ ”

The phantom line depiction in point 4 above also removes specificity of radius on the inner corners of the construction.

6. “with rectangular abrasive pads of thickness T affixed to three sides of the frame.”

As to the pad thickness, break lines or phantom lines can be used to avoid specific definition on pad thickness for example as follows:

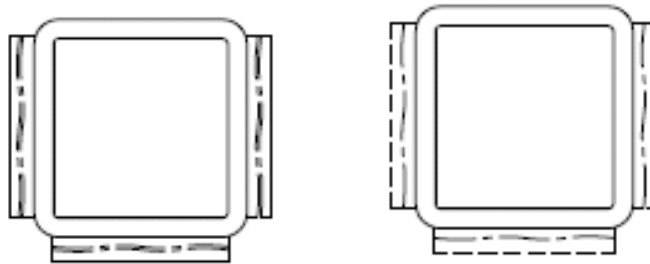

7. “while leaving the curved radius uncovered.”

Had broken lines been used to define the side edges of the abrasive pads as follows, there arguably would have been no specificity as to whether the “curved” corners of the tube had been covered or uncovered; rather, the question would have been whether the undefined corners were covered or uncovered. Further, as pointed out in paragraph 5 above, the whole definition of “curved” could have been avoided.

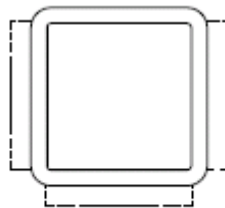

8. “with the fourth side of the frame bare.”

Had phantom lines been used as follows to define the fourth side of the frame, it would seem reasonable to argue that it is not defined as being bare or uncovered-- it is simply undefined.

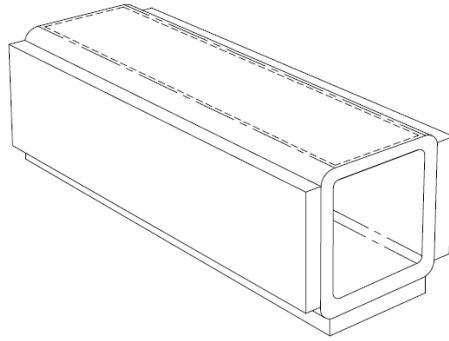

C. Other Variations in the Drawings

Some additional variations are possible with the invention of *Egyptian Goddess*, depicted below. These variations show further control, in addition to the variations of Section B above, that the design patent creator has over the level of detail that may result in a verbal description of the claim during an enforcement action:

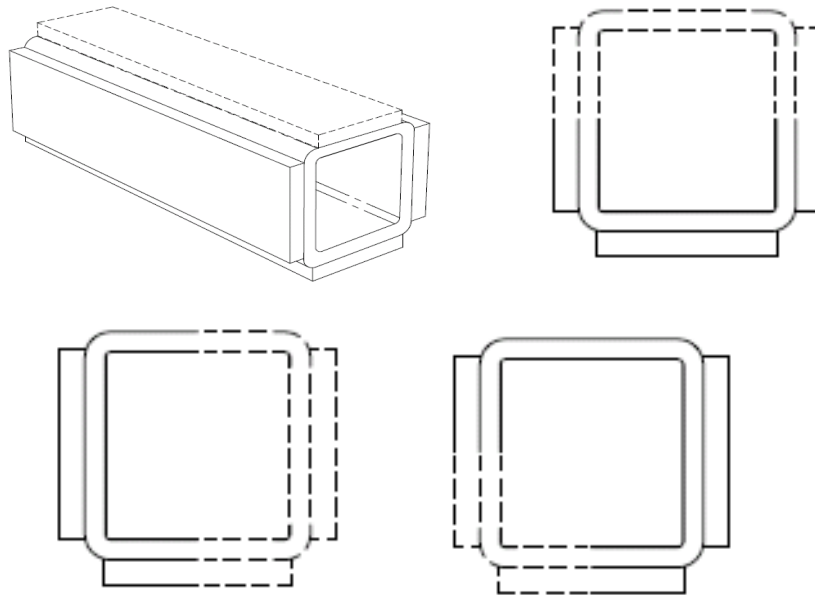

Of course, multiple phantom line and broken line combinations can be used in the same embodiment in a design application.

D. Language Variations

Language can be included in the specification and drawings of a design patent, placing emphasis on certain features or to encourage interpretations with respect to the drawings. While the Patent Office may have some objections depending on the precise statement made, there is specific allowance of some language variations.⁸⁴

Consider some of the following possible techniques:

1. Title of application and claim as a “portion” of a structure. For example, “portion of a shoe” or “portion of a nail file.”
2. Incorporate “comprises” language in figure characterizations, for example “Fig. 2 comprises a perspective view of the claimed design.”
3. Switch the order of a drawing definition, for example, “a perspective view of the design comprises the features shown in Fig. 1.”
4. With respect to a blank surface, say that no claim is made as to whether the surface is blank or not. For example, “Fig. 3 is a top view of the claimed design; no assertion being made as to whether the interior of the blank surface has a feature thereon.”
5. Use of a “characteristic features” clause, within the specification.

Of course, the Patent Office will not necessarily allow all of the above, and the Patent Office may be inconsistent from Examiner to Examiner as to what is acceptable.

⁸⁴ §1503.02 Manual of Patent Examining Procedure, 8th ed., rev. 7, p.1500-5.

E. Ballooning Costs?

Whether or not multiple embodiment design applications lead to unacceptable costs, is, in part, a matter of how the designs are prepared. When the drawing set is based upon CAD drawings, implementing variations with broken lines and/or phantom lines is fairly straightforward with minimal additional cost. Because all embodiments can be included in a single initial application filing, the cost of including the possibility of multiple embodiments is relatively low.

Of course, the U.S. Patent Office will restrict between multiple embodiments. In each follow-up filing, however, a filing fee of a minimal additional cost (\$220) is required on a continuing basis to maintain the pendency of all the alternative designs. Also, since each issued patent will last 14 years from its date of issuance, advantage can be obtained. And, notably, design patents in the U.S. do not have maintenance fees.

VIII. Brief Comments Comparing Design Patent Protection with Protection by either Copyright and/or Unfair Competition Principles

In this section, some brief observations are made to allow comparison of protection under design patent principles to copyright and unfair competition principles. Theoretically, all three forms of protection may be available for the same subject, in some instances. It will be assumed for purposes of the following comments that the article at issue is a “useful article” or an “article of function,” as was the case of the design patent articles above.

A. Copyright

Of course, typically the protection of a useful article under copyright law will be as a “pictorial, graphic or sculptural” work and would be subject to the “separability” requirement of a useful article.

If recognized as protected, however, tests for infringement would generally be more favorable than that for a design patent. For example, generally the test for copyright infringement is a two-part test involving: (1) proof of copying, sometimes demonstrated by access and substantial similarity; and (2) proof that “expression” was taken and used. Since copyright law protects “derivative works,” a general application of the infringement test is more “open ended” than the test for infringement of a design patent, at least as stated by the Federal Circuit with its “deception” requirement.

An issue is whether one can expect to get the useful article protected and recognized as “separable.” In general, it has been these authors’ experiences that the Copyright Office will almost never register a useful article for protection, as long as the useful article does not clearly include some long recognized “art” component. The Copyright Office position with respect to registration will be a repeated summary statement that the design of the article at issue is inseparable. The Copyright Office will maintain this position even if two identical, fully functional, articles are submitted, the only difference between the two being their ornamental appearances. (These authors would assert that in this situation, it is illogical for the Copyright Office to assert no separability, but the Copyright Office will stand its ground).

Of course, a copyright is theoretically enforceable even if the Copyright Office has refused a registration. However, trying to get a court to view a subject as separable, when

the Copyright Office has repeatedly refused to recognize it as such, may be similar to trying to push a rope.

There is at least some tendency for the courts to take somewhat analogous positions, with useful articles only being recognized as separable if it can be demonstrated that there is a market for the article independent of its function. For example, a decorative tie-up post for a horse might be sold as a lawn ornament, independently whether it is expected a horse would ever be tied to it.

B. Unfair Competition

Also, in theory selected features of a useful article can be protected under trade dress or unfair competition principles, as source indicating. Generally, the courts will require proof of “acquired distinctiveness,” i.e. secondary meaning. This proof includes a demonstration that the product or feature depicted is indicative of source to the relevant market. It is likely a substantial marketing investment will be needed, in many instances, to accomplish this effect. The marketing will need to be guided by persons familiar with exactly what proof will be needed to establish “acquired distinctiveness” in the context of an unfair competition assertion.

The exclusivity provided by the design patent can provide the necessary time period to establish the acquired distinctiveness. However, for many designs, it is unlikely it will happen without a direct marketing effort.

If “acquired distinctiveness” is eventually obtained and established, then at least some of the harsh effects of the various of federal court decisions discussed above may be derailed by the “likelihood of confusion, mistake or deception as to source, sponsorship, approval, or affiliation” portion of the infringement test under the Lanham Act.

The courts will be reluctant under unfair competition principles to associate secondary meaning with “functional” features. However, when it can be demonstrated that there are equal, inexpensive manners of design available by which to avoid the likelihood of confusion, then there may be at least some hope in obtaining protection by way of this approach.

IX. Summary and Conclusions

The Federal Circuit’s decisions in *Egyptian Goddess* and follow-up cases indicate that the celebrations following *Egyptian Goddess* may have been a bit premature. The Federal Circuit has said that it is up to the district court’s discretion to use highly detailed verbal characterizations of design patent drawings for purposes of assisting in applying the ordinary observer test. The Federal Circuit has approved conclusions by a district court that features are purely functional, without substantial review. The Federal Circuit is inconsistent with applications of its analyses, upon a closer look.

Product designers will not be satisfied with relying upon Federal Circuit direction for the amount of protection their business efforts need. Patent attorneys will need to modify approaches to design patent drawings and descriptions to account for this.