

The Federal Circuit recently handed down its *en banc* ruling in the design patent case *Egyptian Goddess, Inc. v. Swisa, Inc.*, (Fed. Cir. 2008). The Federal Circuit's ruling substantially changed what constitutes proof of infringement in design patent cases. The Federal Circuit held that its quarter-century old, judicially-created, "point of novelty" test should no longer be used in analyzing design patent infringement. This Federal Circuit opinion breathes new life into design patents, broadening the potential scope of patented designs.

The Federal Circuit's removal of the "point of novelty" test to prove infringement leaves the patent holder with the burden of proving only the "ordinary observer" test. The "ordinary observer" test requires a showing that the accused infringing design and the patented design are substantially the same to deceive the ordinary observer.

This white paper will discuss how the *Egyptian Goddess* case ended up in front of an *en banc* panel of the Federal Circuit; the Federal Circuit's analysis supporting its ruling; and the potential practical impact of that ruling.

Egyptian Goddess, Inc. ("Egyptian Goddess") sells nail care, skincare and body care products in kiosks at malls and through its on-line store. *Egyptian Goddess* is the owner of a design patent for a four-sided fingernail buffer. U.S. Design Patent 467,389 ("the '389 patent") is titled "Nail Buffer." Figures 1 and 4 from the '389 patent are shown below.

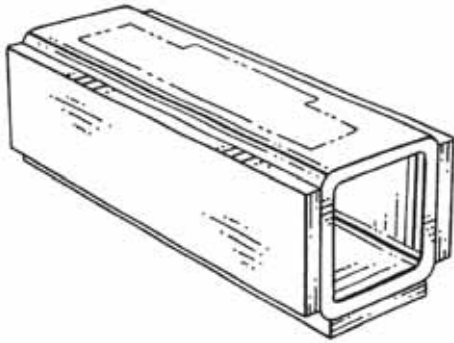

Figure 1
D467,389

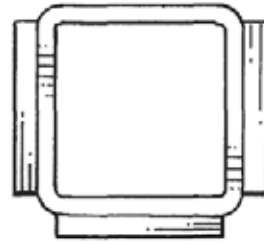

Figure 4
D467,389

As shown in the figures of the '389 patent, the four-sided fingernail buffer has buffing surfaces on three of the four sides with no buffer on the fourth side.

Swisa, Inc. ("Swisa") also sells nail care, skincare and body care products in kiosks at malls and through its on-line store. One Swisa product is a four-sided nail buffer. A drawing of the Swisa buffer at issue in this case is shown below.



Unlike the claimed design from the '389 patent, the Swisa buffer has buffing surfaces on all four sides.

On March 2, 2003, Egyptian Goddess sued Swisa, Inc. ("Swisa") in the Northern District of Texas for design patent infringement. Based in part on the fact Swisa's product has buffers on all four sides and the patent only shows buffers on three sides, Swisa filed a motion for summary judgment of noninfringement. The District Court in

ruling on the motion for summary judgment applied the then-current Federal Circuit case law on evaluating a design patent for infringement. Specifically, the District Court, citing the Federal Circuit decision in *Goodyear Tire & Rubber Co. v. Hercules Tire & Rubber Co.*, 162 F.3d 1113 (Fed. Cir. 1998), ruled that the plaintiff must prove both “that the accused device is ‘substantially similar’ under the ‘ordinary observer’ test, and that the accused device contains ‘substantially the same points of novelty that distinguished the patented design from the prior art.’”

The District Court focused primarily on the “point of novelty” test. Egyptian Goddess argued the points of novelty were the combination of four design elements: (1) open and hollow body; (2) square cross section; (3) raised rectangular pads; and (4) exposed corners.

The District Court did not discuss Swisa’s contentions on the “point of novelty” because the Court felt it could decide the motion based simply on Egyptian Goddess’s points of novelty. The District Court held that the closest prior art (“the Nailco patent”) included all the design elements of the ‘389 save one. The Nailco patent included an open and hollow body, raised rectangular pads and open corners. (*See* figures 1 and 2 from the Nailco patent below.)

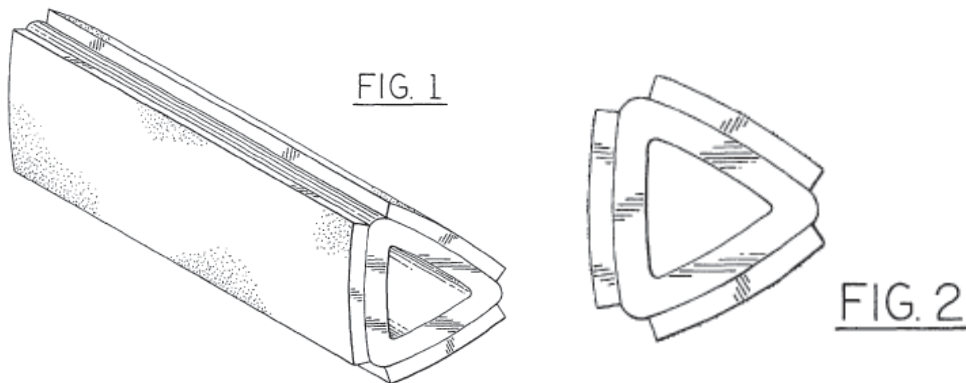

The District Court ruled that Egyptian Goddess could not include these three design elements as novel as they already existed. The District Court determined the only “point of novelty” in the Egyptian Goddess patent was transforming the triangular cross-section of the Nailco design to the square cross-section in the ‘389 patent.

The District Court ruled that a fourth side with a pad (Swisa’s product) is not substantially similar to a fourth side without a pad (the ‘389 patent) and granted Swisa’s summary judgment motion. Egyptian Goddess appealed to the Federal Circuit.

At the Federal Circuit, a divided panel affirmed the District Court’s summary judgment ruling. Oddly, the majority of the panel did not affirm the District Court’s ruling based on the District Court’s reasoning. The majority easily could have by simply determining that District Court’s determination of the “point of novelty” of the ‘389 patent was correct and that Swisa’s design did not include the “point of novelty,” and therefore Swisa did not infringe. But without any explanation as to why it was needed, the majority decided to add an additional prong to the then existing Federal Circuit “point of novelty” test.

The majority of the panel in affirming the ruling added to the “point of novelty” test the “non-trivial advance” test. The majority added the “non-trivial advance” test completely on its own as neither party briefed or argued adding such a test. What the majority now required, in addition to the “ordinary observer” test and the “point of novelty test,” was that the patent owner must prove “for a combination of individually know design elements to constitute a “point of novelty” the combination must be a non-trivial advance over the prior art.” In a vigorous dissent Judge Dyk attacked the majority’s opinion. Judge Dyk argued that the majority was combining an invalidity

obviousness test with the infringement test and that the majority's ruling found no support in Federal Circuit case law.

Upon losing its appeal, and because of the never before described "non-trivial" advance test, Egyptian Goddess filed a combined petition for panel rehearing or rehearing *en banc*. The Federal Circuit granted the petition for rehearing *en banc*.

The Federal Circuit in granting the petition ordered the parties to brief the following three questions:

(1) Should "point of novelty" be a test for infringement of design patent?

(2) If so, (a) should the court adopt the non-trivial advance test adopted by the panel majority in this case; (b) should the "point of novelty" test be part of the patentee's burden on infringement or should it be an available defense; (c) should a design patentee, in defining a point of novelty, be permitted to divide closely related or ornamentally integrated features of the patented design to match features contained in an accused design; (d) should it be permissible to find more than one "point of novelty" in a patented design; and (e) should the overall appearance of a design be permitted to be a point of novelty? *See Lawman Armor Corp. v. Winner Int'l, LLC*, 449 F.3d 1190 (Fed. Cir. 2006).

(3) Should claim construction apply to design patents, and, if so, what role should that construction play in the infringement analysis? *See Elmer v. ICC fabricating, Inc.*, 67 F.3d 1571, 1577 (Fed. Cir. 1995).

In addition to the briefing by the parties there were 29 amici curiae briefs. Oral argument before the Federal Circuit occurred on June 2, 2008. The majority of the

discussion during oral argument involved the validity of the “point of novelty” test and not on the new non-trivial advance test.¹

On September 22, 2008, the Federal Circuit published its *en banc* decision in the Egyptian Goddess case. The Federal Circuit held that the “point of novelty” test should no longer be used in analyzing design patent infringement, and that the “ordinary observer” test was the only test for infringement.

The Federal Circuit rests its *en banc* opinion on the Supreme Court ruling in *Gorham Comp. v. White*, 81 U.S. 511 (1871). In *Gorham* the patent was for a design for the handles of tablespoons and forks. The Supreme Court explained that the purpose of providing designs protection was that the original appearance of an article may increase its “salable value.” The focus of the law was to protect the appearance not to protect the utility of the design. The Supreme Court provided the “ordinary observer” test by holding that,

[I]f in the eye of an ordinary observer, giving such attention as a purchaser usually gives, two designs are substantially the same, if the resemblance is such as to deceive such an observer, inducing him to purchase one supposing it to be the other, the first one patented is infringed by the other.

The Court in developing this test addressed the issue of combination of elements stating, “[a] patent for a product is a distinct thing from a patent for the elements entering into it, or for the ingredients of which it is composed, or for the combination that causes it. . . . [W]e think the controlling consideration is the resultant effect.”

The Federal Circuit, in throwing out its “point of novelty” test, discussed how the test came into being. The “point of novelty” test was first formally introduced in *Litton Systems, Inc. v. Whirlpool Corp.*, 728 F.2d 1423 (Fed. Cir. 1984). The Federal Circuit in

¹ Oral argument at the Federal Circuit can be heard at oralarguments.cafc.uscourts.gov.

Litton held that proof of similarity under the “ordinary observer” test is not enough to prove infringement. The Federal Circuit further required the accused design to appropriate the novelty of the claimed design.

Swisa argued that the “point of novelty” test should not be abandoned because the joint novelty test was prescribed by Supreme Court case law. Specifically, Swisa argued that *Smith v. Whitman Saddle Comp.*, 148 U.S. 674 (1893), a Supreme Court case decided roughly 20 years after *Gorham*, required the “point of novelty” test. But the Federal Circuit in its *en banc* decision explained that *Whitman Saddle* was not inconsistent with *Gorham* and did not add an additional “point of novelty” test to *Gorham* to prove infringement.

In *Whitman Saddle*, the patent was for a design for saddles. In the saddle’s design the inventor had combined the front end of a saddle well known at the time with the back end of another type of saddle well known at the time. There was a feature to one end of the saddle that was new to that kind of saddle. The Supreme Court in this case did not believe this design involved “genius or invention.” Moreover, the Court discussed that if the one feature that was new to the design of the saddle thereby making it potentially patentable, then there was no infringement because the defendant’s saddle did not include that feature.

In *Whitman Saddle*, the court stressed that there was a wealth of prior art saddles, implied that all of the features of the saddle may have been combined by others before, and that “the difference was so marked that in our judgment the defendants’ saddle could not be mistaken for the saddle of the complainant.” The focus continues to be on whether an ordinary observer would be deceived.

After addressing the *Whitman Saddle* opinion, the Federal Circuit then described how to apply of the “ordinary observer” test. First, in some instances the claimed design and the accused design will be sufficiently different that it is clear that the two designs would not appear substantially the same to the ordinary observer. Second, in other cases where the accused design and the claimed design are not plainly dissimilar, the ordinary observer analysis will benefit from a comparison of the claimed and accused design with the prior art. In such a comparison the differences between the claimed and accused designs that might not be noticeable in the abstract can become significant to the ordinary observer familiar with the prior art.

The burden of proof for infringement remains with the patentee. But if the accused infringer elects to rely on the comparison of prior art as part of its defense to infringement, the accused must come forward with the prior art.

After a short discussion concerning the proper role of claim construction in design patent cases,² the Federal Circuit applied its described analysis of an ordinary observer to the facts in the *Egyptian Goddess* case.

In applying its new standard the Court looked at the *Swisa Product*, the patented design and the 2 closest pieces of prior art.

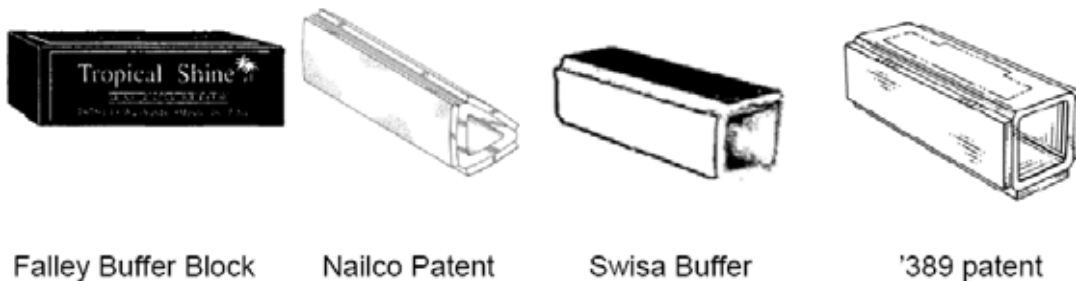

² The District Court recognized the continuing role of claim construction but left the level of detail of that construction within the District Court’s discretion.

The question the Federal Circuit asked was would an ordinary observer, familiar with prior art, be deceived into believing the Swisa Buffer is the same as the patented design. After describing the opinions of the parties experts, the Federal Circuit held that an ordinary observer would not be deceived that the Swisa buffer was the '389 buffer. Thus, the District Court's grant of Summary Judgment was affirmed.

The Federal Circuit's decision, removing the "point of novelty" test, has the potential to provide greater protection to design patent holders. Before *Egyptian Goddess*, an accused infringer could show the court a difference between the patented design and the prior art and classify the difference as a point of novelty. Once accomplished, the accused infringer need only show its product does not include that "point of novelty" and therefore does not infringe regardless of whether an ordinary observer would be deceived. Now the analysis goes back to what the Supreme Court originally provided—are the two designs, taken as a whole, substantially similar that an ordinary observer would be deceived to purchase one design believing it to be the other.